



MS6720

Features

- **Combination hand-held and fixed projection scanner**
- **Fully automatic scanning operation**
- **Stationary stand included; adjustable stand also available**
- **Superior ergonomics**
- **Concentrated omnidirectional scan pattern**
- **Programmable depth of field**
- **Easy programming**

Shown with optional adjustable stand

Metrologic's MS6720 is the first laser bar code scanner to truly bridge the gap between omnidirectional fixed projection and hand-held scanners. It incorporates fixed projection performance and patented 20-line scan pattern into the comfortable, ergonomic styling of the popular hand-helds. With this design, Metrologic has engineered a scanner that transcends any other on the market today.

The MS6720 utilizes a unique, patented infrared sensor and control scheme for hands-free projection scanning and fatigue reduced hand-held operation. Whether operators choose to present small items to the scanner or transport the lightweight scanner to bulkier items, the MS6720 is the perfect choice for

many applications.

Included with the MS6720 scanner is a stationary stand, which is ideal for applications where the MS6720 is being used mostly as a hand-held scanner. This stand was designed for ease of use while still providing sufficient room for fixed presentation. An optional adjustable stand is also available and provides 7 rotational and 9 tilting positions as well as a removable wall mount cup.

The MS6720 features both short-range and long-range activation, user-friendly programming, reliability and versatility. Operators are sure to appreciate the convenience and flexibility of the MS6720.

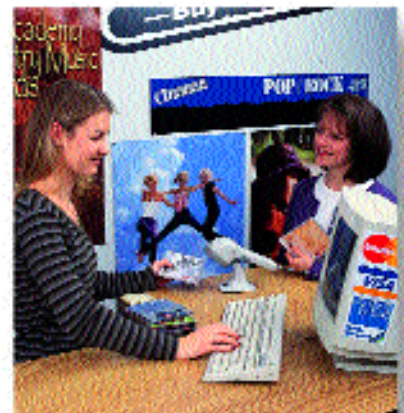

MS6720

OPERATIONAL

Light Source	Visible Laser Diode 675 nm \pm 5 nm or 650 nm \pm 10 nm
Laser Power	0.681 mW (peak)
Depth of Scan Field (programmable)	0 mm - 203 mm (0" - 8") for 0.330 mm (13 mil) bar code at default setting
Width of Scan Field	50.8 mm (2") @ face; 178 mm (7") @ 203 mm (8")
Scan Speed	1000 scan lines per second
Scan Pattern	5 fields of 4 parallel lines (omnidirectional)
Number of Scan Lines	20
Minimum Bar Width	0.145 mm (5.7 mil)
Decode Capability	Autodiscriminates all standard bar codes; for other symbologies call Metrologic
System Interfaces	PC Keyboard Wedge, RS232, OCIA, Light Pen, IBM 468X/469X
Print Contrast	35% minimum reflectance difference
Number Characters Read	Up to 80 data characters
Roll, Pitch, Yaw	360°, 60°, 60°
Beeper Operation	3 tones or no beep
Indicators (LED)	Red = laser on, ready to scan Green = good read

MECHANICAL

Height	216 mm (8.5")
Depth-Handle	28 mm (1.1")
Depth-Head	75 mm (2.9")
Width-Handle	48 mm (1.9")
Width-Head	77 mm (3.0")
Footprint On Stand	100 mm x 135 mm (3.9" x 5.3")
Weight	380 g (13.4 oz)
Termination	10 pin modular, RJ45 connector
Cable	Standard 1.1 m (3.5') retracted coil cord

ELECTRICAL

Input Voltage	5 VDC \pm 0.25 V
Power	1.1 W @ 5V
Operating Current	220 mA @ 5V
DC Transformers	Class 2; 5 VDC @ 300 mA
Laser Class	CDRH: Class IIa; EN60825-1:1994/A11:1996 Class 1
EMC	FCC Class B

ENVIRONMENTAL

Operating Temperature	0°C to 40°C (32°F to 104°F)
Storage Temperature	-40°C to 60°C (-40°F to 140°F)
Humidity	5% to 95% relative humidity, non-condensing
Light Levels	Up to 4842 Lux (450 footcandles)
Shock	Designed to withstand 1 m (3.1') drops
Contaminants	Sealed to resist airborne particulate contaminants
Ventilation	None required

Specifications subject to change without notice.
Printed U.S.A., Copyright January 2000.
Metrologic, All rights reserved.
MLPN: DSMS6720



USA
Metrologic Instruments, Inc.
Tel. 1-800-ID-METRO
Fax 1-856-228-6673
info@metrologic.com

Europe
Metrologic Instruments GmbH
Tel. 49-89-89019-0
Fax 49-89-89019-200
info@europe.metrologic.com

South America
Metrologic Instruments
Tel. 5511-5505-6568
Fax 5511-5505-1681
info@sa.metrologic.com

Brazil
Metrologic do Brasil Ltda.
Tel. 5511-5505-2396
Fax 5511-5507-2301
info@br.metrologic.com

Asia
Metrologic Asia (Pte) Ltd.
Tel. 65-842-7155
Fax 65-842-7166
info@sg.metrologic.com

Scan Area

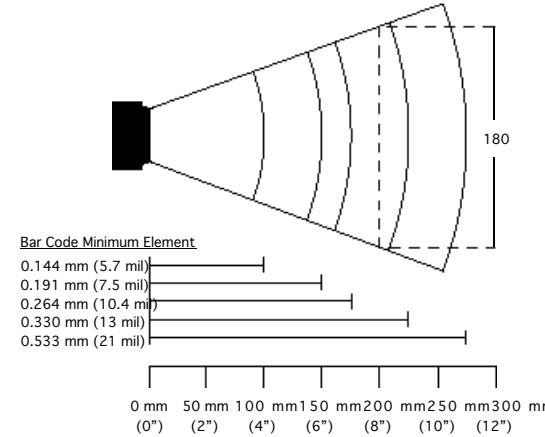

Dimensions

